

NIR LASER SCANNING CONFOCAL MICROSCOPY

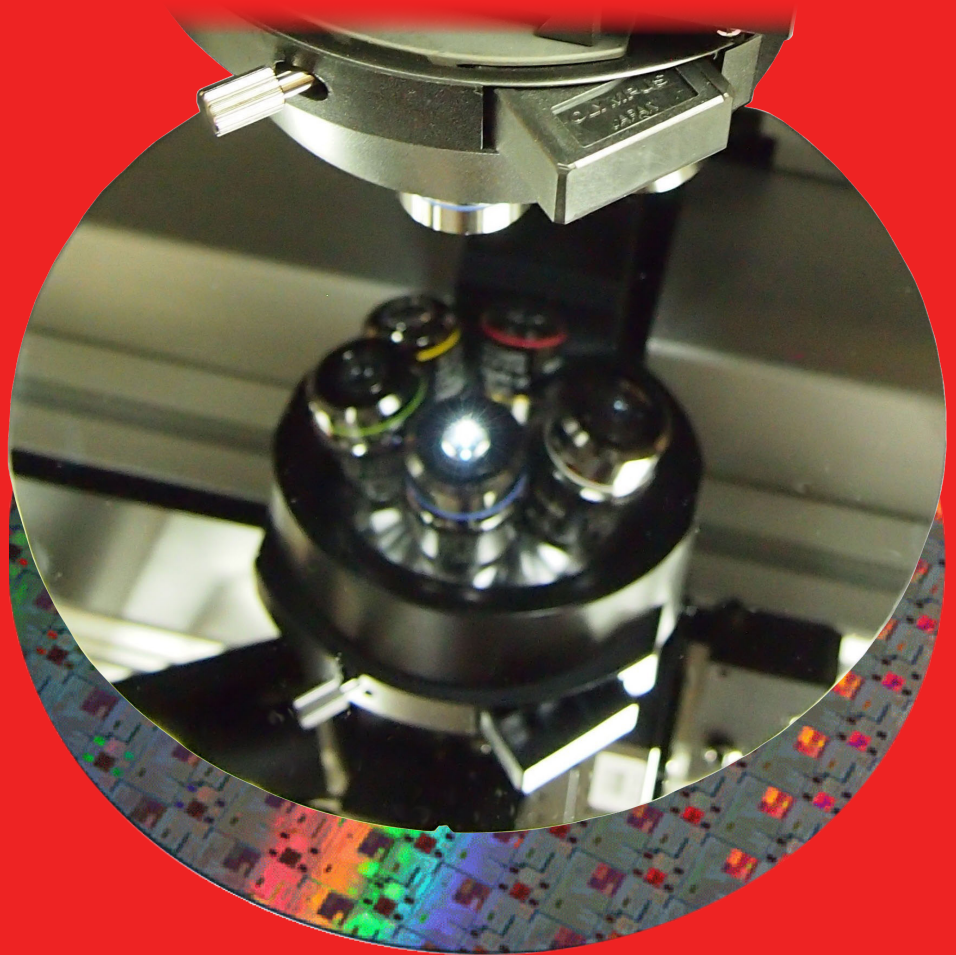

is a world leader in the design, manufacture and integration of OEM and complete microscopy automation solutions for the biomedical, metrology, electronics, semiconductor, and flat panel display markets.

CONFOCAL MICROSCOPY

WDI's IRLC and LSCM systems employ a near-infrared (NIR) laser, specialized infrared optics, and confocal imaging technology to create the ideal non-destructive, semiconductor subsurface imaging tool. The combination of a NIR laser and optics with a scanning confocal microscope offers several advantages over conventional widefield infrared microscopy systems. First and foremost is the ability to acquire clear, high resolution images from deep within Si and other similar materials. NIR laser scanning confocal technology also permits deeper imaging through heavily doped substrates, improved spatial resolution, and faster data acquisition.



10X image of wafer pattern imaged at the surface

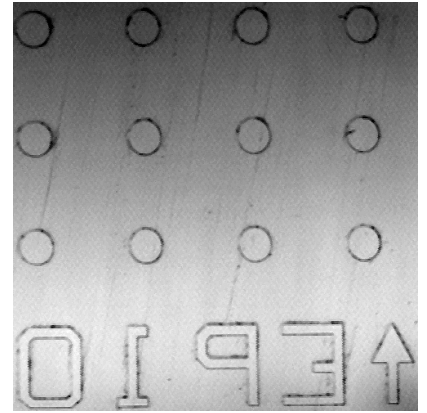

10X image of wafer pattern imaged through 700 μm from the backside

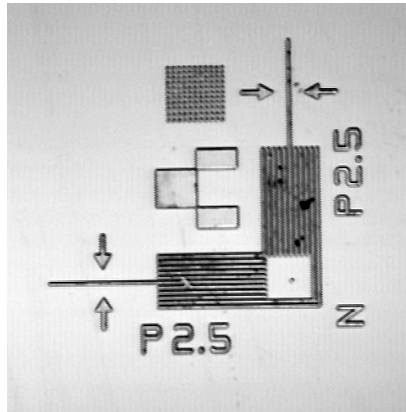

20X image of wafer pattern imaged at the surface

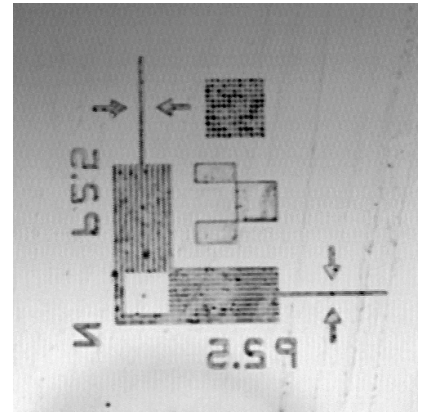

20X image of wafer pattern imaged through 700 μm from the backside

OPTIMIZED FOR SILICON

To ensure the highest resolution and sharpest images, all system components, optical elements, and objectives have been designed and selected for optimal transmission of NIR wavelengths and imaging through Si. Features such as advanced photo detection and unique objective “correction collars”, coupled with component automation for precision motorization of the objectives, XY stage, ND filters, Z position, and illumination, ensure accurate, fast and simple image collection.



NIR INSPECTION FOR FAILURE ANALYSIS

NIR confocal microscopy is ideally suited for use at various points within the failure analysis (FA) workflow because it is non-destructive and allows inspection of both Si bulk integrity and active level/layer areas. The imaging technique has been applied to Flip Chip, WLCSP, and doped wafers. Other applications include integrity inspection after bonding, sacrificial oxide layer inspection after etching, inspection for chipping and cracks after grinding or dicing, and inspecting SIP (system in package), 3D mounting, or CSP (chip scale packages).

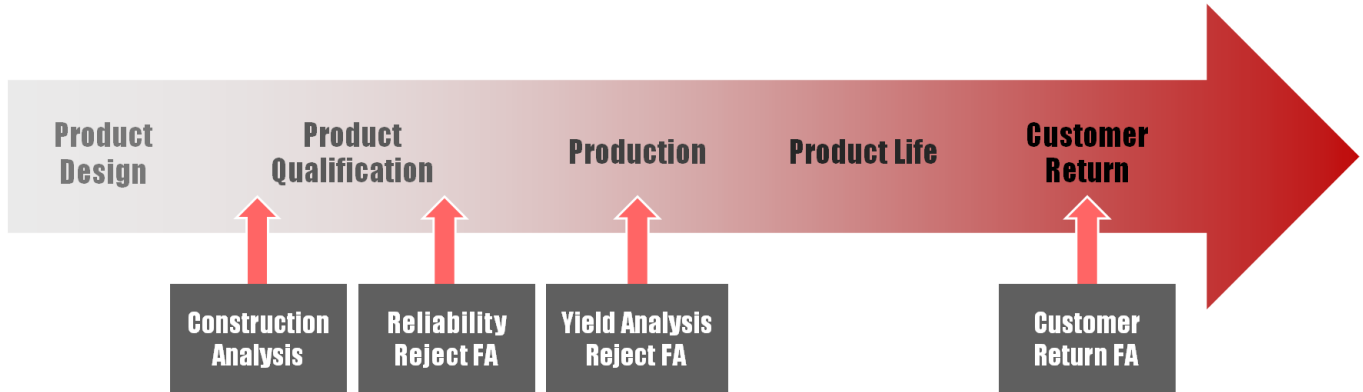

VERSATILE AND ADAPTABLE

CMOS imaging sensors (CIS) often have a protective film or colour filter layer over the pixel area. With conventional brightfield techniques, only the surface detail is visible. However, using NIR confocal microscopy, the structures beneath these areas are clearly visualized.

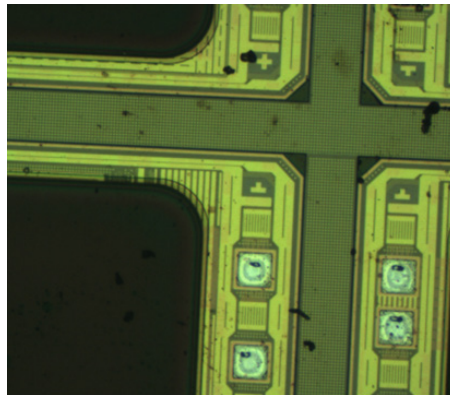

5X brightfield image of CIS device (front)



20X NIR confocal image of CIS device (front)

Frontside imaging through the metal pad of a device is not possible, and backside imaging can be difficult due to heavy doping and depth of the active layer. NIR confocal microscopy permits rendering from the backside, resulting in high resolution subsurface images.

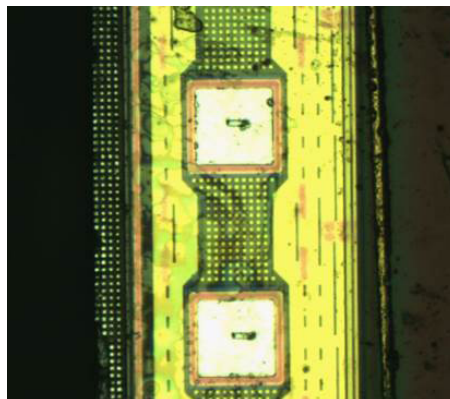

10X brightfield image of doped device (front)

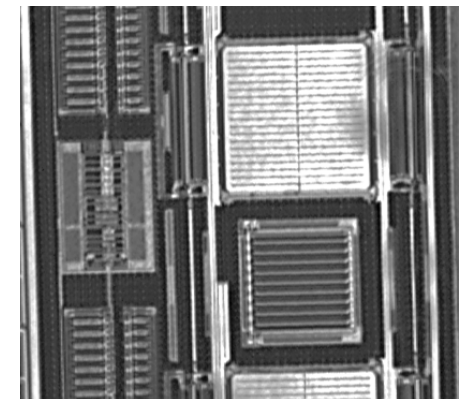

20X NIR confocal image of doped device (back)

DUAL OBSERVATION

IRLC and LCSM systems include both a colour CMOS camera and NIR laser scanning confocal microscope. This combination allows imaging both at the surface and deep within a wafer or device. Switching between these observation methods is a one-click process. Since the systems utilize WDI's advanced autofocus (ATF), OOA (optical offset adjuster), and ZAA (Z-axis actuator) technology, the wafer or sample remains in constant focus regardless of changes in observation method or surface metrology, even during movement.

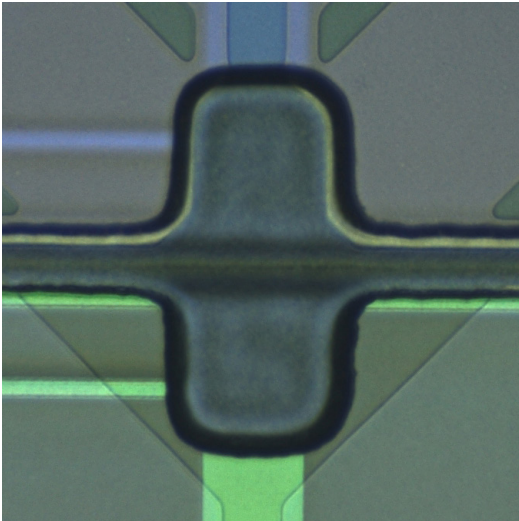

20X brightfield surface image of a thin film transistor (TFT) array with transistors hidden under the black matrix

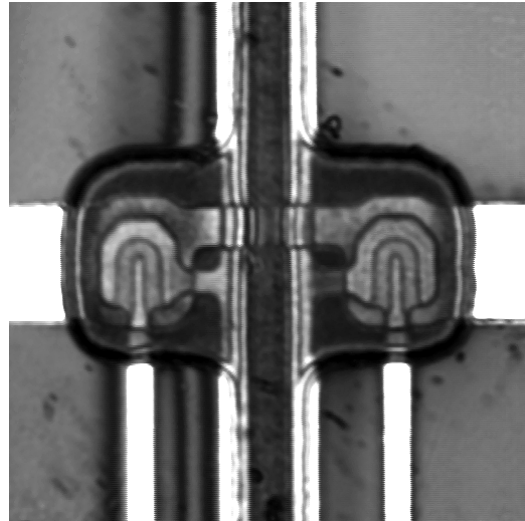

20X NIR confocal image of the TFT array revealing the transistor structure beneath the black matrix

IMAGING OF DOPED DEVICES

Due to light scattering, heavily doped wafers and devices may be difficult and often impossible to image with conventional widefield IR techniques, particularly if the active layer is deep. WDI's systems are dedicated to overcoming this issue, providing superior high quality, high resolution, subsurface images at all magnifications.

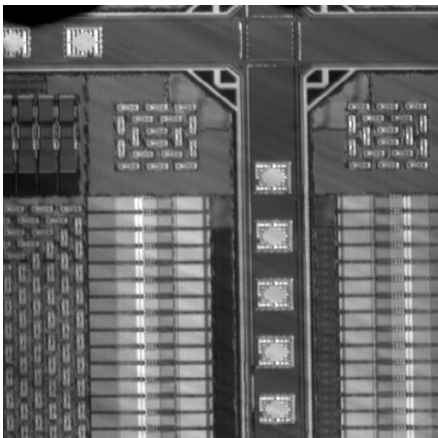

10X NIR confocal image of doped silicon device taken approx. 400 μm below the surface

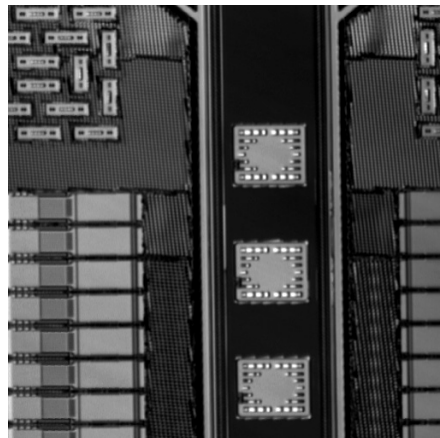

20X NIR confocal image of doped silicon device taken approx. 400 μm below the surface

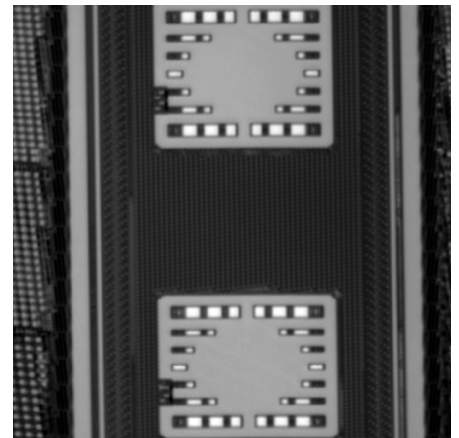

50X NIR confocal image of doped silicon device taken approx. 400 μm below the surface

INTUITIVE SOFTWARE

All systems feature powerful yet intuitive software permitting efficient data collection. Operation of the system, including system adjustments for illumination, magnification, XYZ stage position, and focus offset, are easily made. The software also features advanced image acquisition options, such as maximum Z projection, image stacking and image sequences. Data can be easily exported to popular imaging processing software such as Imagej and Matlab.

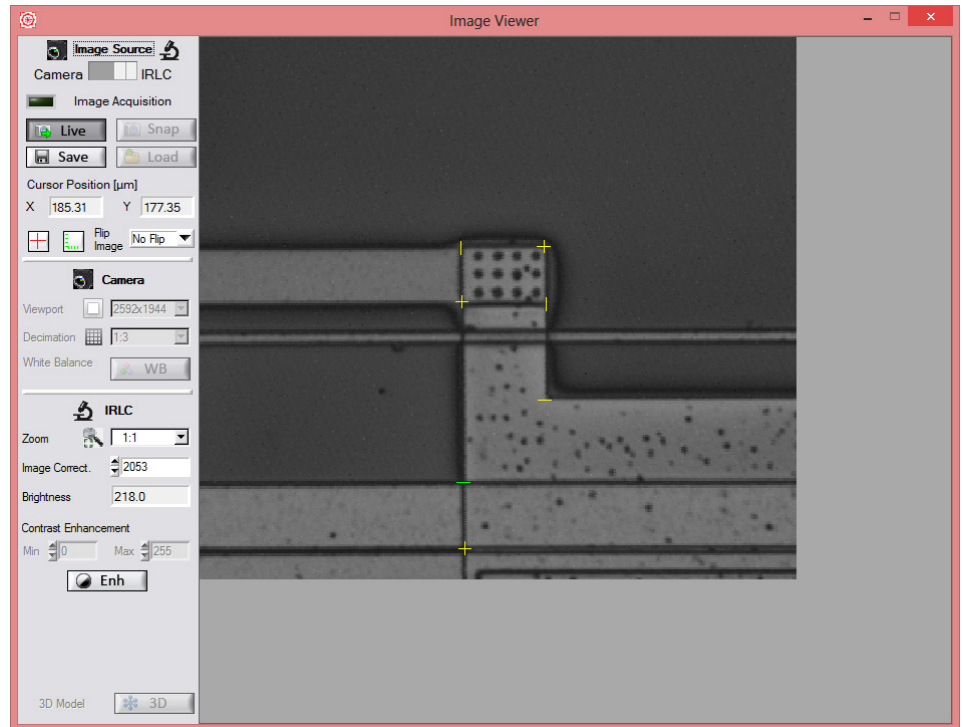
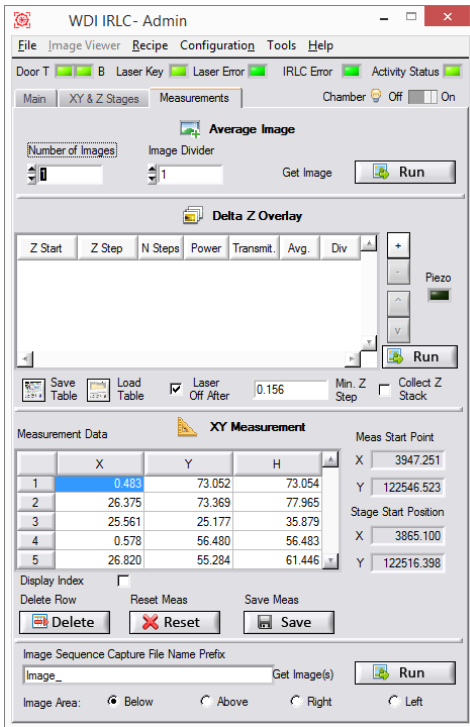

AUTOMATED ACQUISITION

By combining integrated motorization with autofocus with optional software, the systems can run automated acquisition routines. These routines may be applied to a single die or multiple dies, permitting the complete automation of the imaging process. The creation and execution of imaging recipes for wafers and both IC strip and tray packages is also possible. Once created, recipes can be executed against other individual samples or entire trays or strips of devices, ensuring accurate and repeatable inspection and greater overall efficiency.

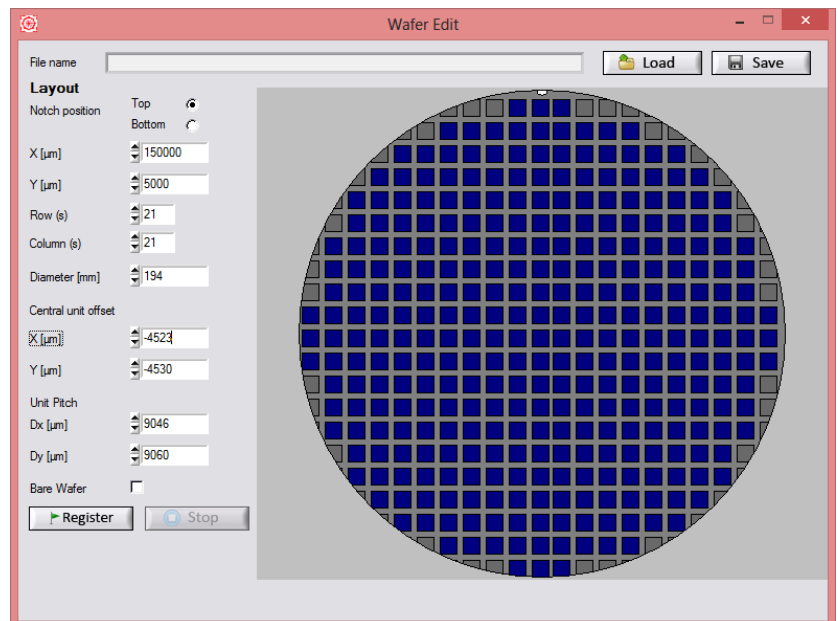

IRLC IMAGING SYSTEMS

The IRLC is a NIR confocal imaging system designed for applications that require support for 300 mm wafers, 100X magnifications, and complete autonomous operation. Built on a solid granite foundation, the IRLC is the ultimate tool for subsurface imaging.

- ✓ Confocal scanner (500 mW, 1155 nm)
- ✓ Motorized variable beam attenuator
- ✓ Motorized Z jack course focus
- ✓ Motorized ZAA fine focus ± 5 mm
- ✓ ATF 6 sensor, 660 nm with OOA
- ✓ Motorized objective turret
- ✓ 5X, 10X, 20X, 50X, 100X
- ✓ Motorized XY 300 mm linear stage
- ✓ Colour CMOS camera
- ✓ IRLC standalone software
- ✓ Laser safety enclosure

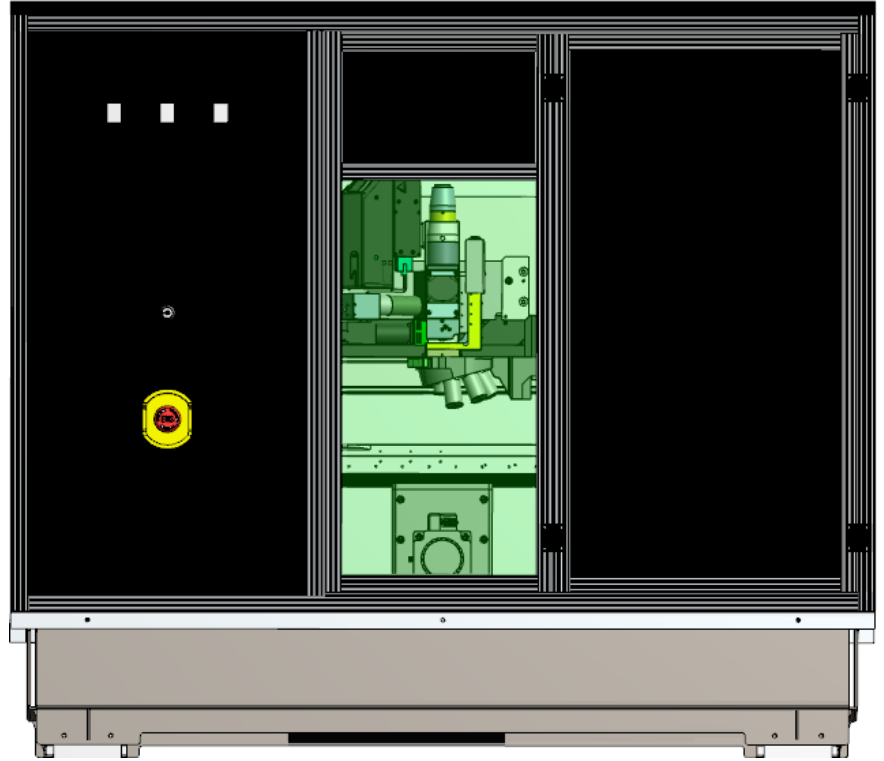

LSCM IMAGING SYSTEMS

The LSCM NIR confocal imaging system offers the capability of the larger IRLC in a smaller tabletop platform. Flexible and adaptable to many applications, it can be configured as a fully automated system, a semi-automated system with a manual stage, or even as an OEM component to be integrated into an existing tool.

- ✓ Confocal scanner (300 mW, 1178 nm)
- ✓ Manual Z jack course focus
- ✓ Motorized ZPS fine focus ± 5 mm
- ✓ ATF 6 sensor, 660 nm with OOA
- ✓ Motorized objective turret
- ✓ 5X, 10X, 20X, 50X
- ✓ Motorized XY 200 mm linear stage
- ✓ Colour CMOS camera
- ✓ LSCM standalone software
- ✓ Laser safety housing

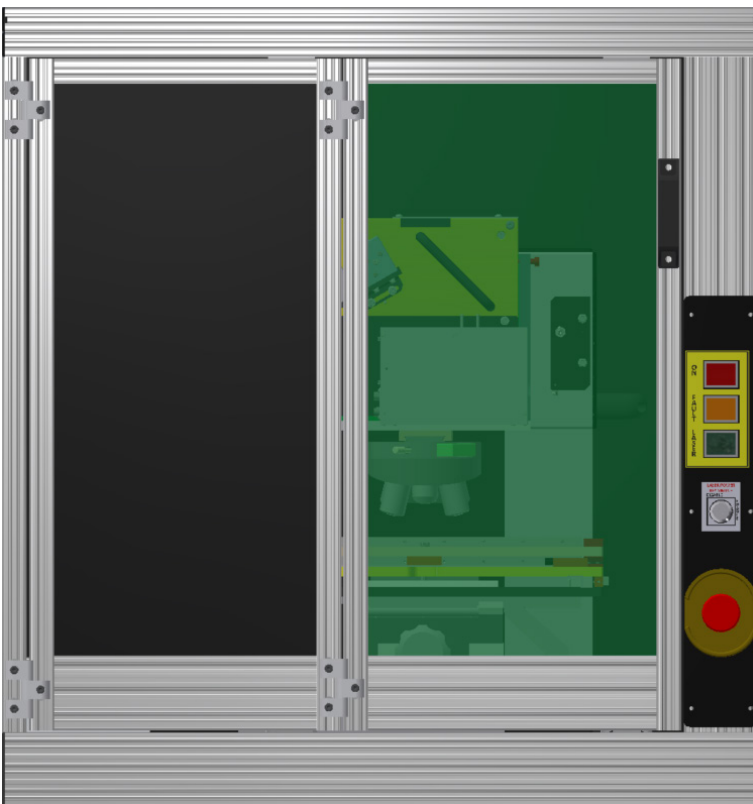

SYSTEM SPECIFICATIONS

CATEGORY	SPECIFICATION	IRLC SYSTEM		LSCM SYSTEM	
General System	System class	Class I			
	Observation methods	NIR laser scanning confocal, conventional brightfield			
	Electrical	3 separate AC outlets, 100-240 V, 50/60 Hz, single phase			
	Current	13.0 A total system			
	Operating temperature	10°C to 30°C ambient			
	Operating humidity	< 70% non-condensing			
	Weight (main unit)	900 kg	175 kg		
Lens Changer	Motorized turret	6 lens capacity			
Z Stage Jack	Stroke	Motorized, 50 mm stroke	Manual, 75 mm stroke		
Motorized Z Actuator (Hybrid ZAA also available for high speed IRLC)	Type	1/32 stepper motor			
	Travel	10 mm			
	Resolution	0.157 µm	0.250 µm		
	Maximum speed	10 mm/sec			
	Maximum load	3.5 kg			
Motorized XY Stage (Manual stage also available for LSCM)	Type	Linear encoder stepper motor			
	Travel	300 mm x 300 mm	200 mm x 200 mm		
	Resolution	0.1 µm			
	Maximum speed	120 mm/sec			
	Accuracy	20 µm/300 mm			
	Repeatability	1 µm			
	Maximum load	1 kg			
Autofocus	Structured light pattern	Line segment			
	Sensor wavelength	658 nm			
	Image detector	Area scan CMOS			
Motorized OOA	Depth range	0 to 800 µm			
Brightfield Illumination	Type	Super bright white LED			
Brightfield CMOS Camera	Size	1/2 inch 2 MP CMOS			
	Resolution	1600 X 1200			
	Frame rate	10 FPS full resolution			
	Bit depth	10 bits			
	Pixel size	4.2 µm X 4.2 µm			
Confocal Illumination	Type	Single mode laser diode			
	Maximum laser power	500 mW	300 mW		
	Wavelength	1155 nm	1178 nm		
	Typical spectral width	5.0 nm	2.3 nm		
Confocal Photodetector	Spectral response range	900 nm ~ 1700 nm			
	Resolution	496 x 500	512 x 512		
	Bit depth	8 bits			
	Virtual pixel size	7.5 µm standard			
	5X	10X	20X	50X	100X ^a
Numerical Aperture	0.1	0.3	0.45	0.65	0.85
Working Distance	23 mm	18 mm	8.3 mm	4.5 mm	1.2 mm
Field Number	22	22	22	22	22
Correction Collar			Yes	Yes	Yes
Glass Thickness Correction			0~1.2 mm	0~1.2 mm	0~0.7 mm

a 100X objective is optional on LSCM.

IRLC SYSTEM DIMENSIONS

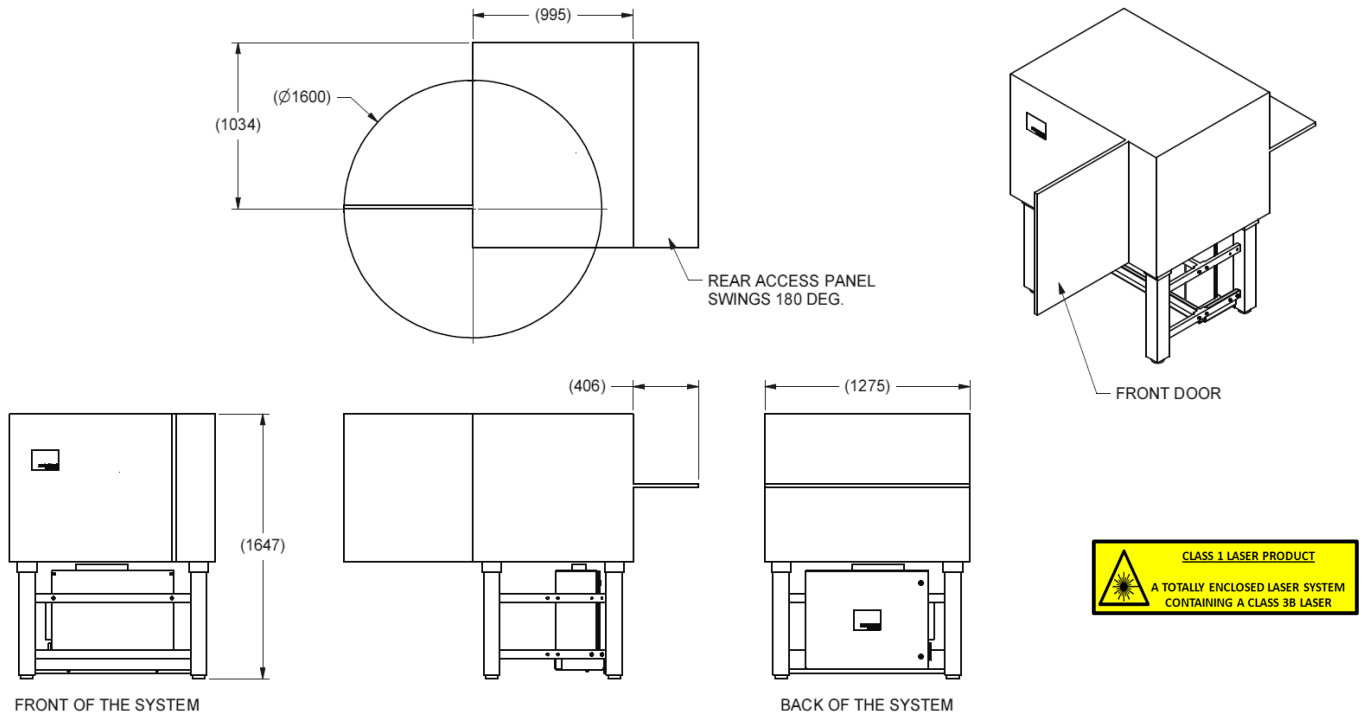

LSCM SYSTEM DIMENSIONS

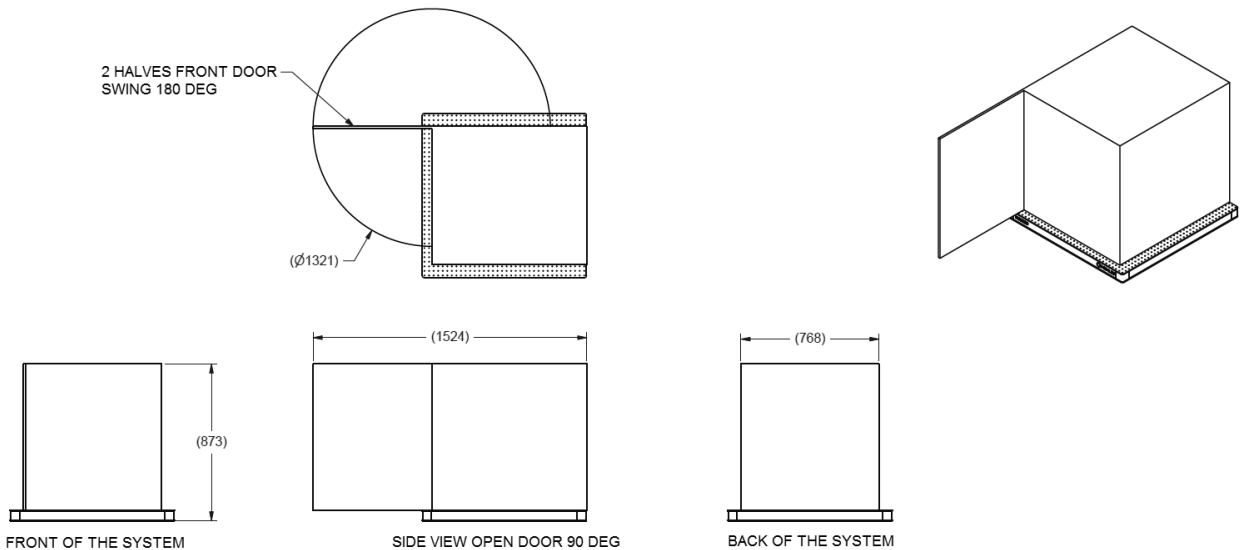

WDI is a world leader in the design, manufacture, and integration of OEM and complete microscopy automation solutions for the biomedical, metrology, electronics, semiconductor, and flat panel display markets. WDI's success lies in an innovative culture and ability to optimize and adapt our technology to customers' specific requirements by listening to their needs and gaining a deep understanding of their processes, applications and goals. WDI employs over 30 optical, electrical, mechanical and software engineers, as well as scientists, who are dedicated to servicing our customers. We have locations in Canada and Poland, with service centers in Taiwan and South Korea. Contact WDI today to see how we can help solve your microscopy automation needs.



✉ sales@wdidevice.com

🌐 www.wdidevice.com

☎ +1 905.415.2734

© 2019 WDI Wise Device Inc. All rights reserved. Design, features, and specifications are subject to change without notice.